

A B C D E F G H J K L M N P

Rev	Description	By	Date
0	Release	JJ	12/26/05

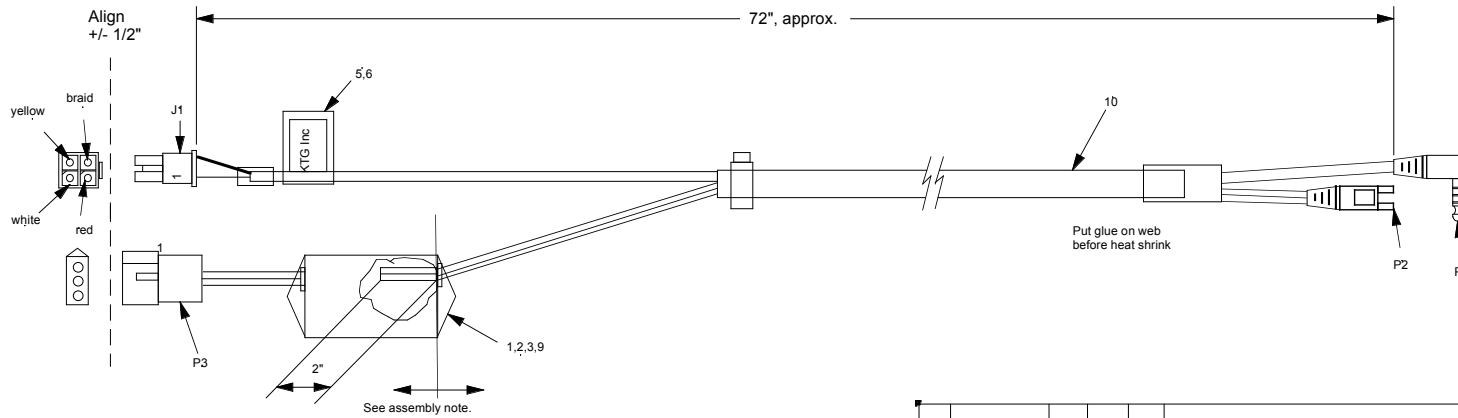

Item	Part #	Rev	Qty	Unit	Description
10	85880	0	1	ea	Harness, HS830
9	85814	0	1	ea	PowerSet-5.9V
8	70007	0	1	ea	Bag, Poly, 5"x14"
7	65200	2	1	ea	Usersheet, cell phone
6	60183	0	1	ea	Label, harness, HS830
5	60049	0	1	ea	label, overlaminating, 1.25 x 3
4	60004	5	1	ea	Label, KTG package label
3	60002	2	1	ea	label, metallized polyester w/laminant
2	55051	0	1	ea	Cover, for TF-1218TX, black
1	30200	0	0.1	mL	Adhesive

CONNECTION DIAGRAM

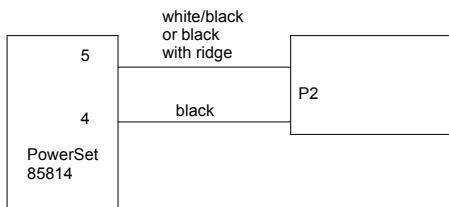

THIS DRAWING IS THE PROPERTY OF THE KENNEDY TECHNOLOGY GROUP, ROSE HILL, KANSAS

Kennedy Technology

REFERENCE 95397	Harness, HS830, cell phone		UNLESS OTHERWISE SPECIFIED: DIMENSIONS ARE IN INCHES TOLERANCES: LINEAR Fractional - 1/32" 0.0 s ± 0.15 0.00 s ± 0.015 0.000 s ± 0.0015 ANGULAR ±0.5 DEG.
SIZE B	CADFILE	DWG NO. 95425	REV NO. 0
SCALE: NONE		EFFECTIVE sn:	
SHEET 1 OF 1		FOR ASSISTANCE CONTACT: vox 316-776-1111 fax 316-776-9035	DRAWN DATE
		CHECKED	DATE

A B C D E F G H J K L M N P