

A B C D E F G H J K

Rev	Description	by	Date
0	release	jj	11/28/06

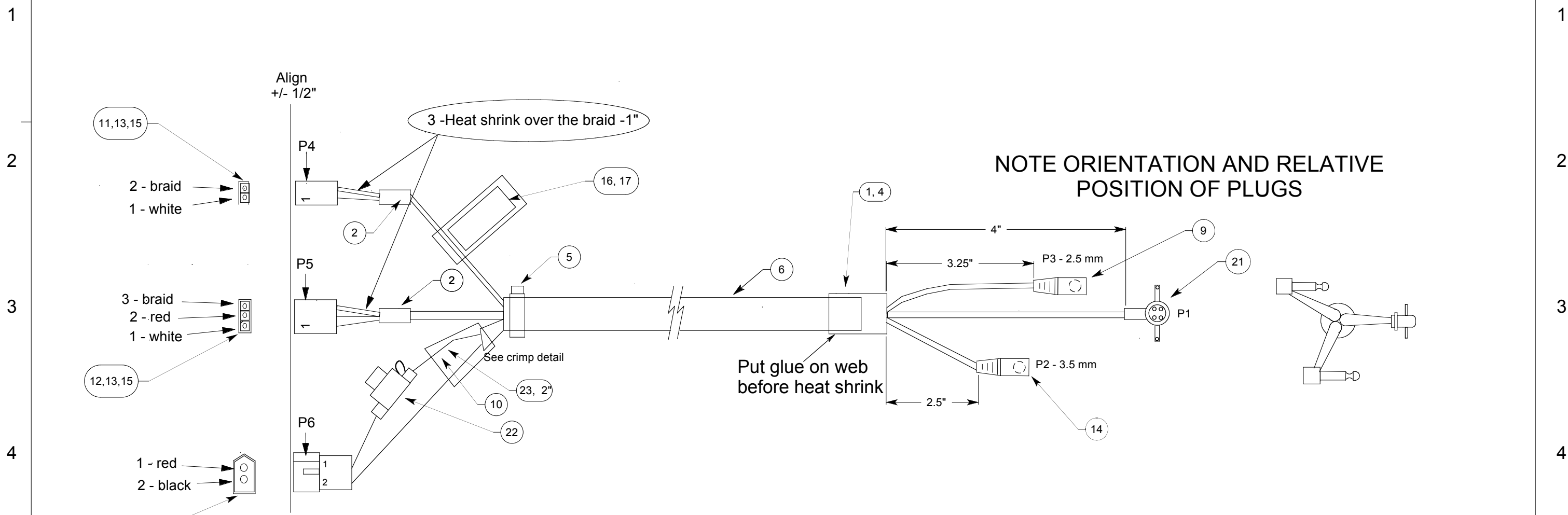

Assembly fuse pigtail and P6 first. Cut cables to P4 and P5 to length so connectors align.

Item	Part #	Rev	Qty	Unit	Description
25					
24					
23	30057	0	2	in	Tubing, heat shrink, 3/16
22	85879	0	1	ea	Fuse Holder from, Garmin, Zumo, Modified harness
21	85878	0	1	ea	Harness, Garmin, Zumo, Modified
20	85225	1	1	ea	Kit, tie wrap
19	70007	0	1	ea	Bag, Poly, 5"x14"
18	65307	0	1	ea	User sheet, Harness, Zumo 550
17	60181	0	1	ea	Label, Harness, Garmin Zumo
16	60049	0	1	ea	label, overlaminating, 1.25 x 3
15	40152	0	3	ea	Terminal, Male, Micro-fit, gold, 26-30 AWG
14	40127	0	1	ea	Cordset, stereo, 3.5mm, Right angle, 72", black
13	40119	0	2	ea	Terminal, Male, Micro-fit, gold, 20-24 AWG
12	40116	0	1	ea	Plug, Micro-fit, 3 circuit
11	40114	0	1	ea	Plug, Micro-fit, 2 circuit
10	40067	0	1	ea	Contact, pin, Hitachi-type
9	40041	1	1	ea	Cordset, 2.5mm, Plug, mono, Rt angle, 72"
8	40025	0	2	ea	Contact, pin, 18-24AWG, 0.062"
7	40015	0	1	ea	plug, 2 conductor
6	30624	0	56	in	Sleeve, polyester, 3/8", black, non-fray
5	30502	0	1	ea	Tie wrap, 4", Black
4	30200	0	0.2	mL	Adhesive
3	30049	0	2	in	Tubing, heat shrink, 1/16
2	30034	0	2	in	Tubing, heat shrink, 1/8"
1	30028	0	1.5	in	Tubing, heat shrink, 1/2"

CRIMP DETAIL

Prior to crimping, remove 1/2 of stranded conductors from black pigtail

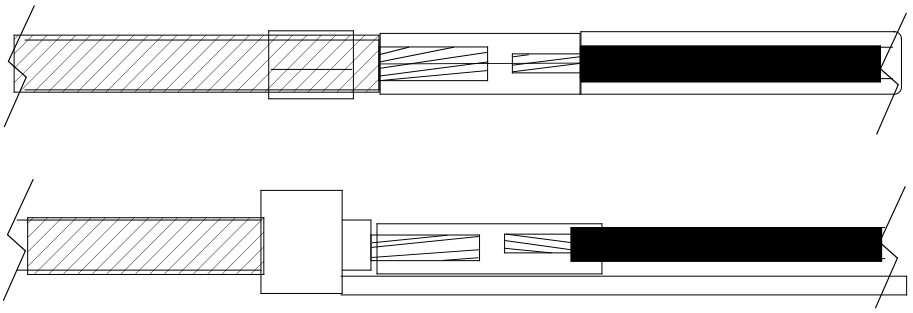

THIS DRAWING IS THE PROPERTY OF THE KENNEDY TECHNOLOGY GROUP, ROSE HILL, KANSAS

Kennedy Technology

UNLESS OTHERWISE SPECIFIED:
DIMENSIONS ARE IN INCHES
TOLERANCES
LINEAR
Fractional - 1/32"
0.0 ± 0.15
0.00 ± 0.015
0.000 ± 0.0015
ANGULAR
±0.5 DEG.

REFERENCE: 95412 Harness, Garmin Zumo 550

SIZE: C CADFILE: DWG NO.: 95423 REV NO.: 0 EFFECTIVE sn:

SCALE: NONE FOR ASSISTANCE CONTACT: DRAWN: DATE:

SHEET 1 OF 1 vox 316-776-1111 fax 316-776-9035 CHECKED: DATE:

A B C D E F G H J K

8