

A B C D E F G H J K L M N P

Rev	Description	by	Date
0	Release	JJ	12/26/05

1
2
3
4
5
6
7
8
9

1
2
3
4
5
6
7
8
9

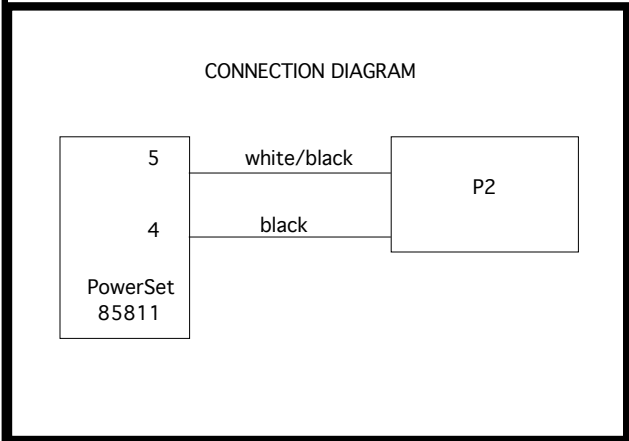
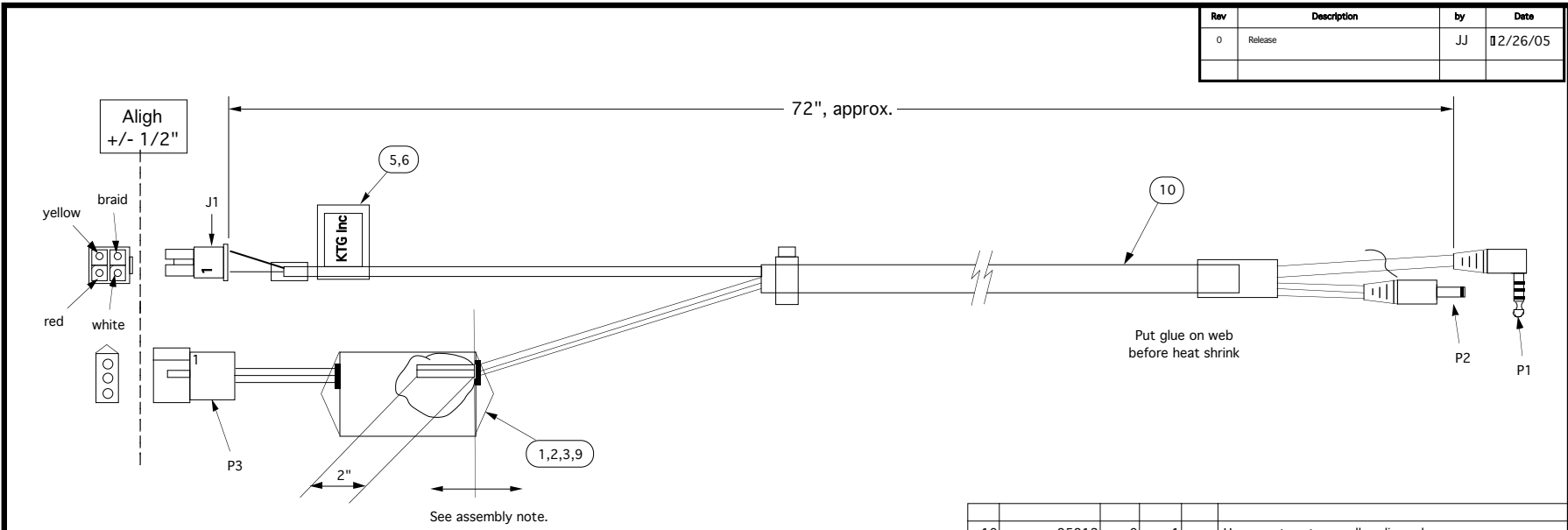

Item	Part #	Rev	Qty	Unit	Description
10	85813	0	1	ea	Harness, tom-tom, cell audio and power
9	85811	0	1	ea	PowerSet-5V
8	70007	0	1	ea	Bag, Poly, 5"x14"
7	65200	2	1	ea	Usersheet, cell phone
6	60159	0	1	ea	Label, harness, TOM-TOM cell phone
5	60049	0	1	ea	label, overlaminating, 1.25 x 3
4	60004	5	1	ea	Label, KTG package label
3	60002	2	1	ea	label, metallized polyester w/laminant
2	55051	0	1	ea	Cover, for TF-1218TX, black
1	30200	0	0.1	mL	Adhesive

THIS DRAWING IS THE PROPERTY OF THE KENNEDY TECHNOLOGY GROUP, ROSE HILL, KANSAS

Kennedy Technology

REFERENCE: 95397 Harness, Tom-tom, cell phone

UNLESS OTHERWISE SPECIFIED:
DIMENSIONS ARE IN INCHES
TOLERANCES
LINEAR
Fractional - 1/32"
0.0 ± 0.15
0.00 ± 0.015
0.000 ± 0.0015
ANGULAR
±0.5 DEG.

SIZE: B	CADFILE	DWG. NO.: 95396	REV. NO.: 0	EFFECTIVE DATE
SCALE: NONE			FOR ASSISTANCE CONTACT:	DRAWN
SHEET 1 OF 1			vox 316-776-1111 fax 316-776-9035	DATE

A B C D E F G H J K L M N P