

Installation Guide

CellSet

MC/GPS-Harley

Kennedy Technology Group, Inc.

email:kennedy@cellset.com
www.cellset.com

DO NOT ATTEMPT THIS INSTALLATION IF YOU ARE COLORBLIND!

The installation instructions cover both **Pre '06**, and **2006 and Later** audio systems.

PRE INSTALLATION

Verify that the bike's audio system is operational. Check audio and radio functions at both the rider and passenger positions.

HARNES INSTALLATIONS

Tools Required

- ◇ Tools required to remove windscreen and faring
- ◇ 1/4" wide blade flat screw driver
- ◇ 1/16" wide blade flat screw driver
- ◇ Thin Needle nose pliers or hemostats (preferred)
- ◇ Iso-Tip, Micro heat gun (Kennedy part # 35021)
- ◇ Razor Blade

Remove the bike's windscreen and the faring. Disconnect the headlamp from the bike's wiring harness.

Pre-'06: Use the 1/4" wide blade flat screw driver to remove Ampseal connectors 27B and 28B (refer to Photos 1 and 2).

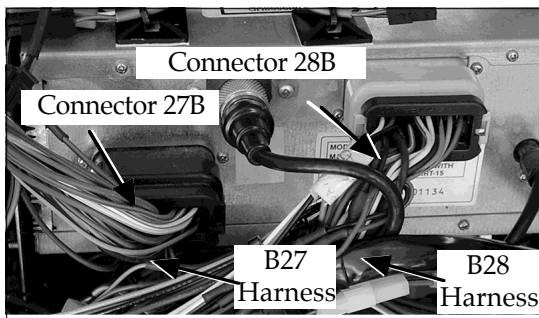

Photo 1 - Pre-'06 Radio, Rear View

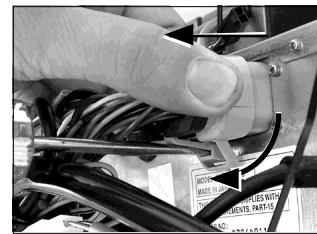

Photo 2 - Pre-'06 Connector Removal

2006 and Later: Connector location is the same. Use your index finger to lift both connectors' retaining tab.

Peel back any protective sheathing on the Harley harness so that at least 6 inches of wire are exposed coming out of connectors 27B and 28B.

Use a 1/16" wide blade flat screw driver to push the Ampseal connector wedge lock tabs away from the red wedge lock as shown in Photo 3. Pull the wedge lock up as shown in Photo 4. *The wedge lock should never be removed from the housing for insertion or removal of the contacts.*

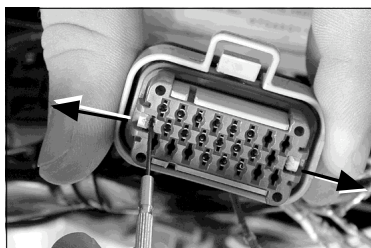

Photo 3 - Connector Disassembly Step 1

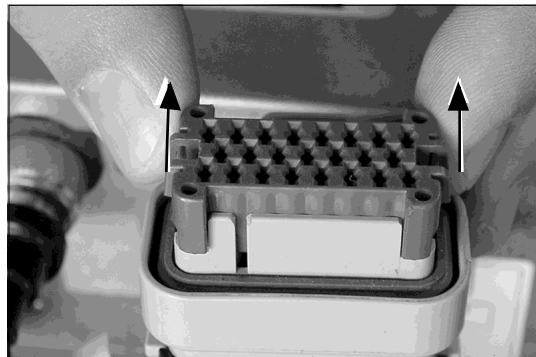

Photo 4- Connector Disassembly Step 2

Technique for removal of Ampseal contacts from the connector housing (refer to Photos 5 and 6):

Grab the wire to be removed (shown in the next section) with needle nose pliers or hemostats. While rotating the wire back and forth over a half turn (1/4 turn in each direction), gently pull the wire until the contact is removed.

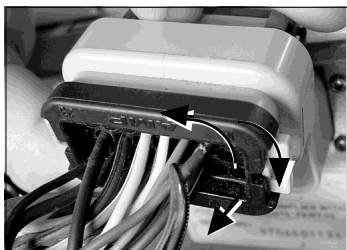

Photo 5- Pin Removal, Step 1

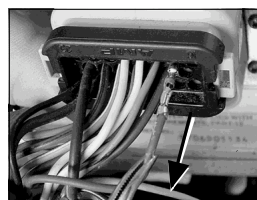

Photo 6- Pin Removal, Step 2

End of Removal Technique

The sequence for installing the harnesses is:

- ◇ Locate and remove the appropriate contact from the Ampseal connector.
- ◇ Place a piece of heat shrink over the corresponding mating pin on Kennedy harness.
- ◇ Press the mating pin and the Ampseal connector contact together (refer to Photo 7 and 8) until the locking tangs on Kennedy harness mating pin disappear into the Ampseal connector contact.

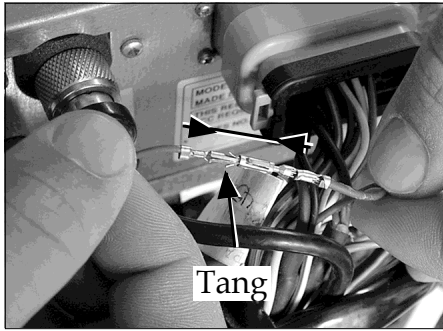

Photo 7- Pin and Socket, pre-Seated

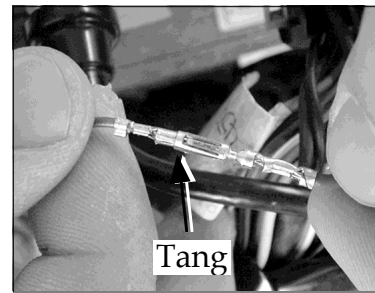

Photo 8- Pin and Socket, Seated

Slide the heat shrink tube back over the mating pair. Center the contact pair within the heat shrink (see Photo 9). Apply heat as shown in Photo 10. Let the heat shrink cool completely before moving the connection.

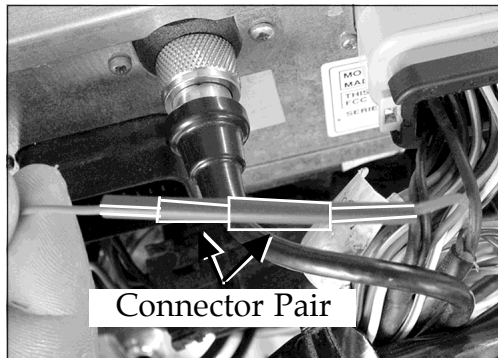

Photo 9- Heat shrink Position



Photo 10- Heat Application

Insert the proper Ampseal contact of the Kennedy Amp harness into the empty position just created.

Installing Kennedy Harnesses part #85910 and 85911

Locate Kennedy harnesses part #85910 and 85911 and 5 pieces of 1/8" diameter x 2" shrink-wrap, from kit part number 85615-10.

Refer to Figures 1 (Pre-'06) and Figures 1a (2006 and Later) on the next page, and make the connections between Ampseal connector 28B and Kennedy harness 85910, and harness 28B and Kennedy Harness 85911.

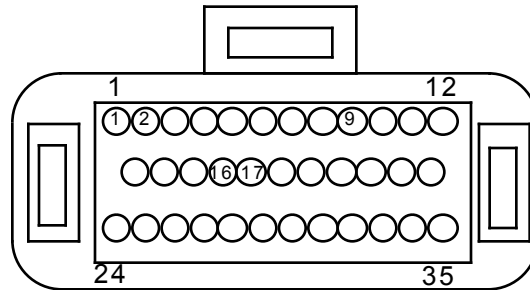
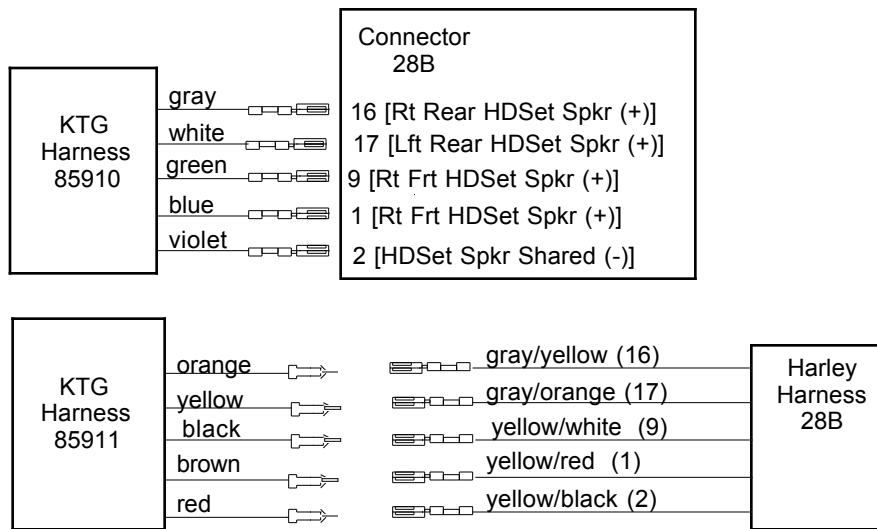

Harness Connector Rear View

Figure 1, Pre-'06 Kennedy Amp harness 85910 and 85911 Connection

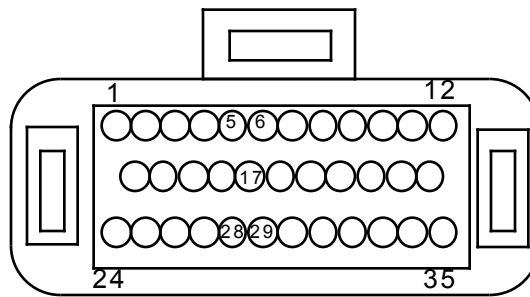
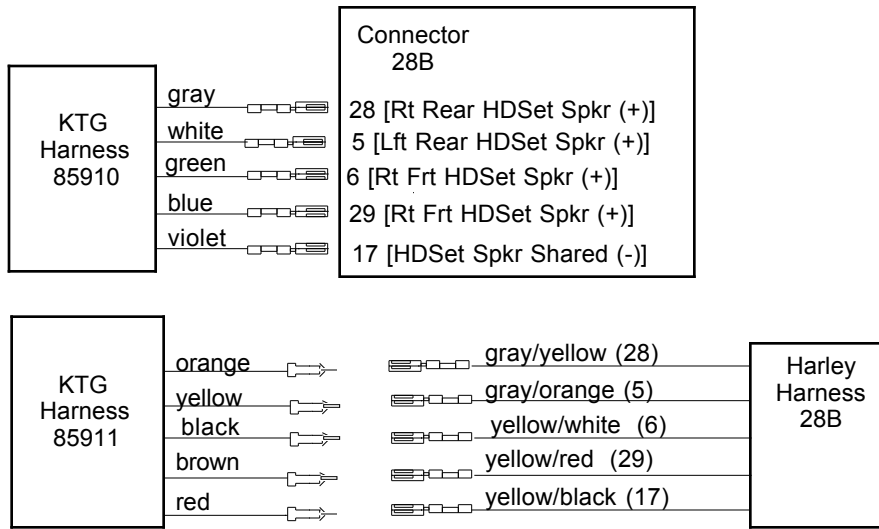

Harness Connector Rear View

Figure 1a, 2006 and Later Kennedy Amp harness 85910 and 85911 Connection

Installing Kennedy Harness part #85909 (For GPS devices that support Bluetooth Cell phone audio)

Locate Kennedy harnesses part #85909 and 3 pieces of 1/8" diameter x 2" shrink-wrap, from kit part number 85615-10.

Refer to Figures 2 (Pre-'06) and Figures 2a (2006 and Later) on the next page, and make the connections between Ampseal connector 28B, harness 28B and Kennedy harness 85909

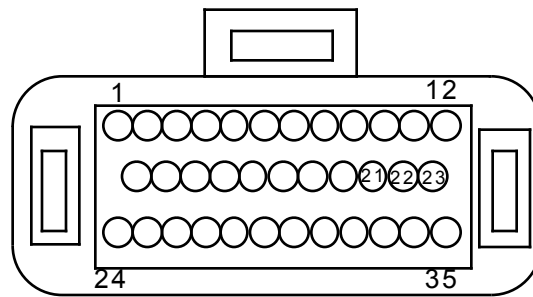
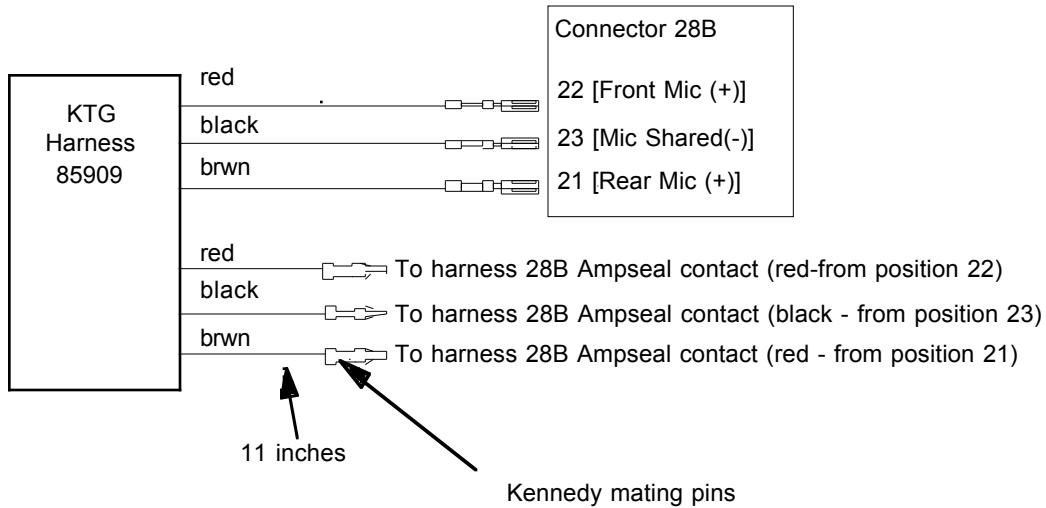

Harness Connector Rear View

Figure 2, Pre-'06 Kennedy harness 85909 Connection

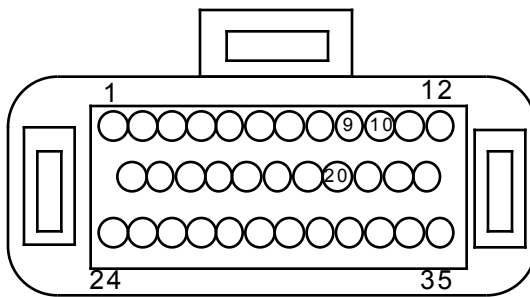
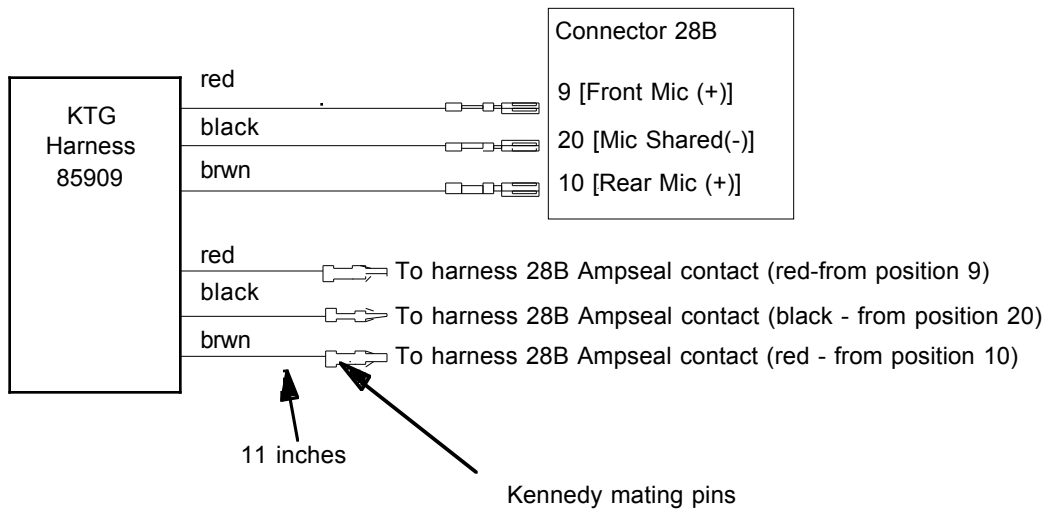

Harness Connector Rear View

Figure 2a, 2006 and Later Kennedy harness 85909 Connection

NOTE: If a contact pair is connected in error, carefully cut the heat shrink down its length with the razor blade and pull it off the mated contacts.

Installing Kennedy Power harness part #85584

Disassemble connector 27B as you did to Ampseal Connector 28B (see Photos, previous pages).

Locate Kennedy harnesses part #85584 and 2 pieces of 1/8" diameter x 2" shrink-wrap, from kit part number 85615-10.

Figure 3, shows the connections to be made between Ampseal connector 27B, Harness 27B, and Kennedy Harness part # 85584. This figure applies to all '98 and later Harley audio systems.

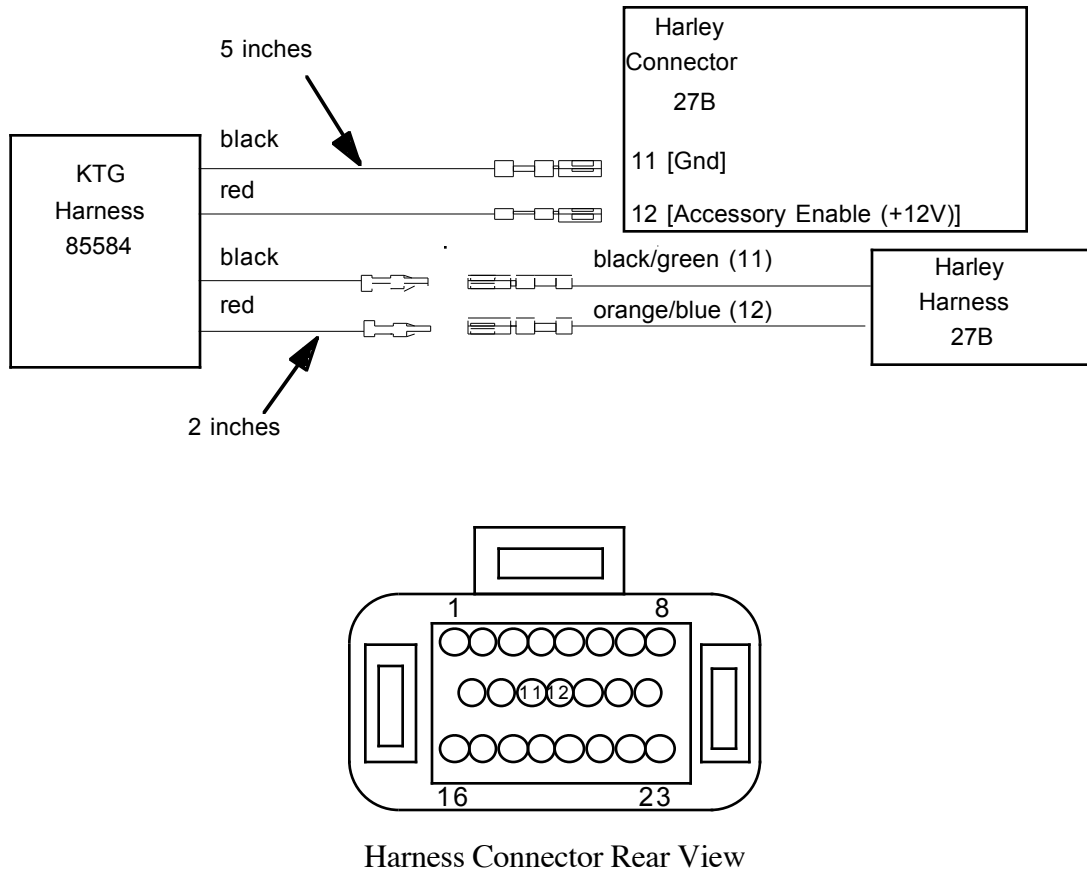

Figure 3, '98 and Later, Kennedy Amp harness 85584 Connection

GO BACK AND REVIEW THE MATING CONTACT WIRE COLORS!

Reassemble the Ampseal connectors by pressing the red wedge lock down until the locking tabs seat. If any Ampseal contact is not seated correctly, the red wedge lock will not close. Push any unseated contact further into the connector.

Plug the harness Ampseal connectors 27B and 28B back into the radio.

MODULE INSTALLATION AND DEVICE HARNESS CONNECTION

For Pre-'06 models, mount the main Kennedy Module to the top of the radio using the Velcro strips provided.

For 2006 and newer models, mount the main unit on top of the radio. Feed long tie wraps through the holes on the Kennedy module's mounting tabs and attach them around the large Harley harness found adjacent to the bike's speedometer and tachometer.

Connect the Kennedy Module to the Kennedy Harnesses as shown below.

Connect the Kennedy GPS and Alert device harnesses to the mating connectors on the main Kennedy Module. Route the device harnesses to the mounted GPS and Alert devices.

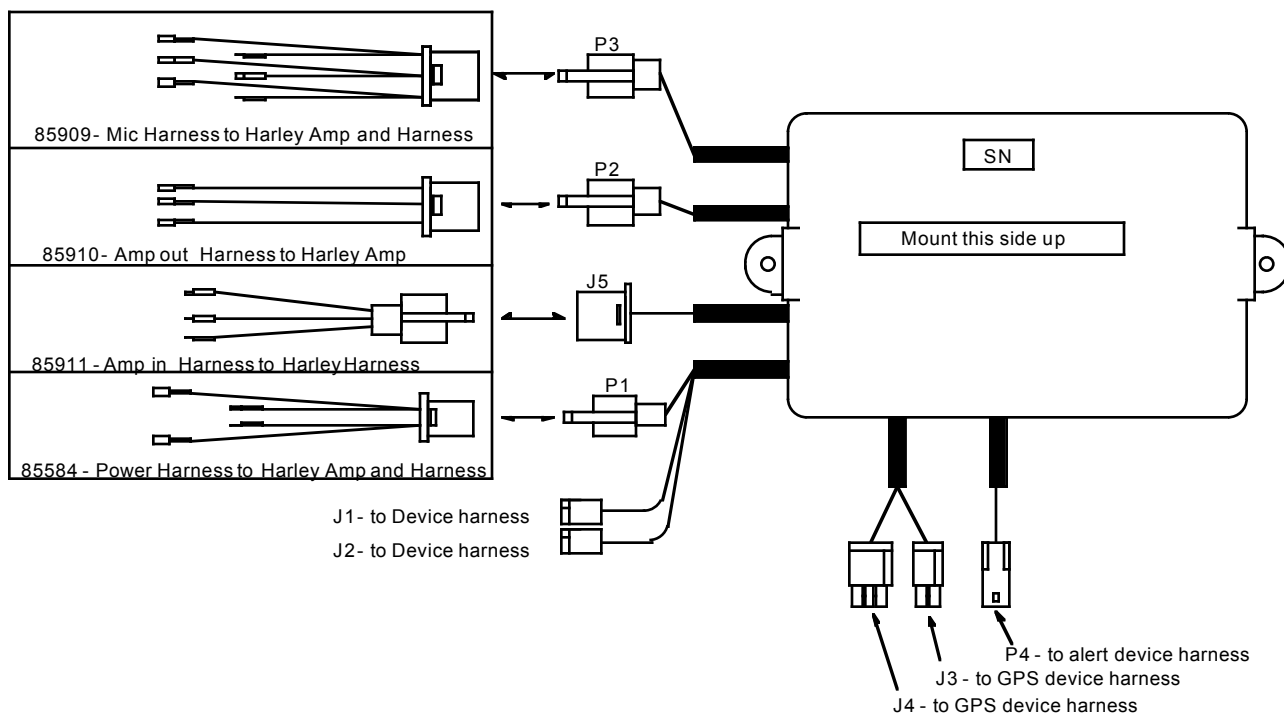

Should you need to disconnect plugs P1, P2, P3, or J5, refer to the [Plug Disconnect Hints](#) at the end of this installation guide.

Refer to the User Guide and test for proper operation

Once proper operation is verified, replace all the Harley harness sheathing and wire-tie the Kennedy Harnesses into place. Reinstall the fairing and windscreen.

Plug-set Disconnect Hints

Press down on the locking tab. Grip the connectors between mating parts with a pair of needle-nosed pliers.

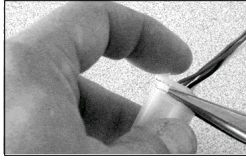

While holding the locking tab down, rock the pliers back...

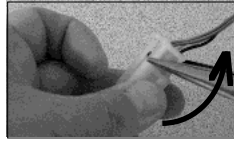

and forth.

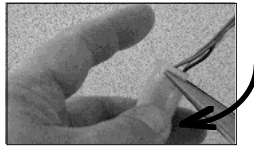

NEVER, NEVER PULL THE WIRES