

PRODUCT SUPPORT INFORMATION

KENNEDY TECHNOLOGY GROUP

RELEASE DATE: 2/28/04 - Document Part #65180R0

Document purpose: To instruct on the mixing and matching of *SingetSets* and *DualSets* and their associated power and device harness.

Part numbers included in this support document:

Part #	Model	Type
95198	SingleSet	Interface
95199	DualSet	Interface
95200	1500	Power harness
95201	1800-US	Power harness
95202	1800-Euro	Power harness
95244	Unterminated	Power harness
95206	IQue Harness	Device harness
95207	Garmin SPill	Device harness
95208	Passport	Device harness
95209	Valentine	Device harness
95210	Cobra	Device harness
95211	Garmin 2610	Device harness

In order to effectively use Kennedy audio interface products, it is important to understand how they can connect. This document exists toward that end. Furthermore, it contains example connections which may prove enlightening.

Not covered in this document are interface connections between the devices listed above and the bike's intercom system; there is not much variation lying therein.

Device Harnesses

All Kennedy Device Harnesses (except the IQue, see note,below) have common connectors that allow them to connect to most Kennedy Interface devices (e.g. *SingleSet*, *DualSet*). Those connectors and their purpose are shown in Figure 1, below.

Note: The IQue Device Harness does not have a device power input, only a connector for the audio output. Power for the IQue is provided by the customer's OEM power adapter via a cigarette lighter connector. If the customer is using a Kennedy IQue Device Harness, he does not need to purchase a corresponding Kennedy Power Harness.

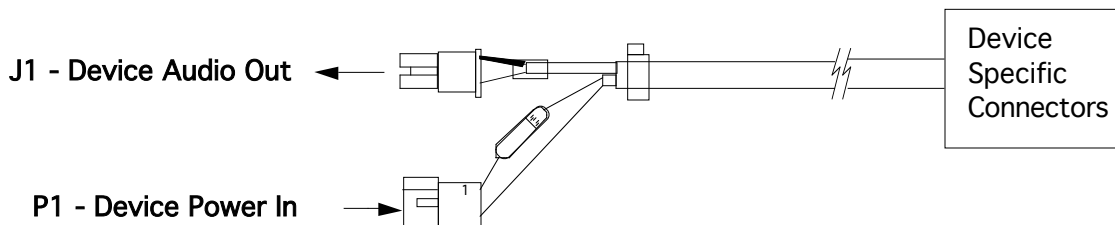

Figure 1. Device Harness Connectors

Power Harnesses

All Kennedy Power Harnesses have a common connector that allows them to be connected to most Kennedy interface devices and Device Harnesses. The currently available models are shown in Table 1, below.

Model	Power Source (see note)	Drawing
GL1800-US	Switched	<p>part number 95201</p>
Unterminated	User selected - see bike manual for appropriate power tie in point.	<p>part number 95244</p>
GL1800-Euro	Switched (when connected to accessory lugs on OEM fuse panel)	<p>part number 95202</p>
GL1500	Switched (when connected to accessory lugs on OEM fuse panel)	<p>part number 95200</p>

NOTE: Switched sources are preferred for radar detectors. Unswitched sources are preferred for GPS devices.

Table 1. Power Harnesses

Connecting Devices to a *SingleSet*

The *SingleSet* is an audio interface device. It is passive (requires no power source) and contains no connectors for power distribution to multiple Device Harnesses. Power is delivered to the device by connecting the Device Harness power connector directly to the Power Harness appropriate to the user's bike and/or preferences.

Please note that "P" and "J" designators do not physically appear on the connectors; they are for reference only.

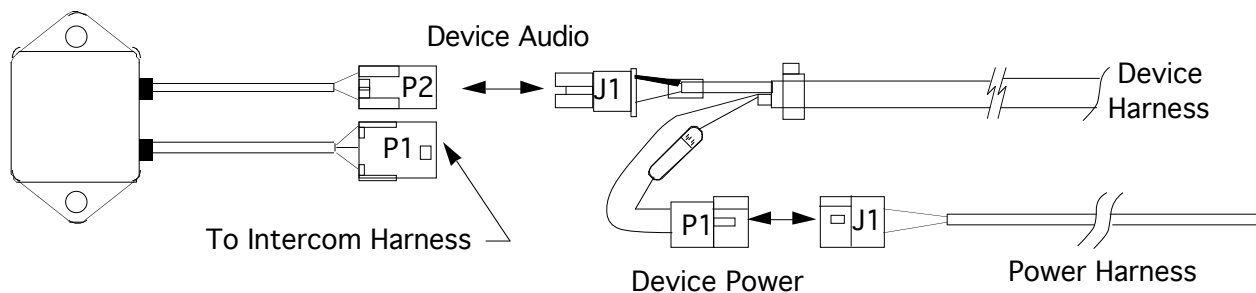

Figure 2. SingleSet Connection

Connecting Devices to a *DualSet*

The *DualSet* is an audio interface device. It is passive and requires no power source. Unlike the *SingleSet*, it contains connectors for power distribution to multiple Device Harnesses.

Figure 3, below, shows a typical configuration for a user who wants a common power source (switched or unswitched) to both devices. Only one Power Harness is used (selected to accommodate the user's bike and/or power preference). The power harness is connected directly to *DualSet*. *DualSet* splits that power to connectors J1 and J2. Both Device Harnesses connect directly to the *DualSet*.

Again, the "P" and "J" designators do not physically appear on the connectors.

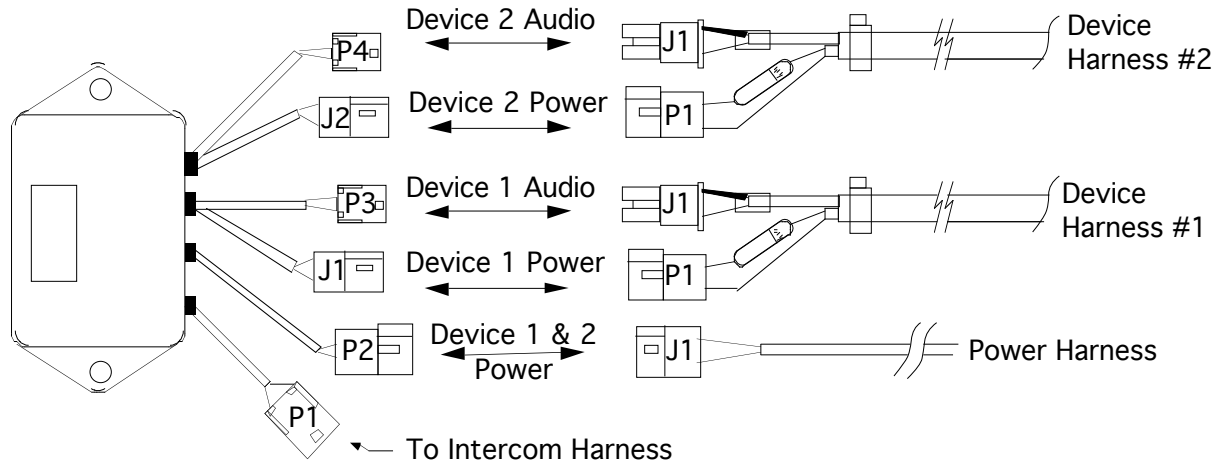

Figure 3. DualSet Connection - same power source

Figure 4, below, shows a typical configuration for a user who wants different power sources (one switched, one unswitched) for each device. Two Power Harness are used (selected to accommodate the user's bike). Each Power Harness is connected directly to the Device Harness.

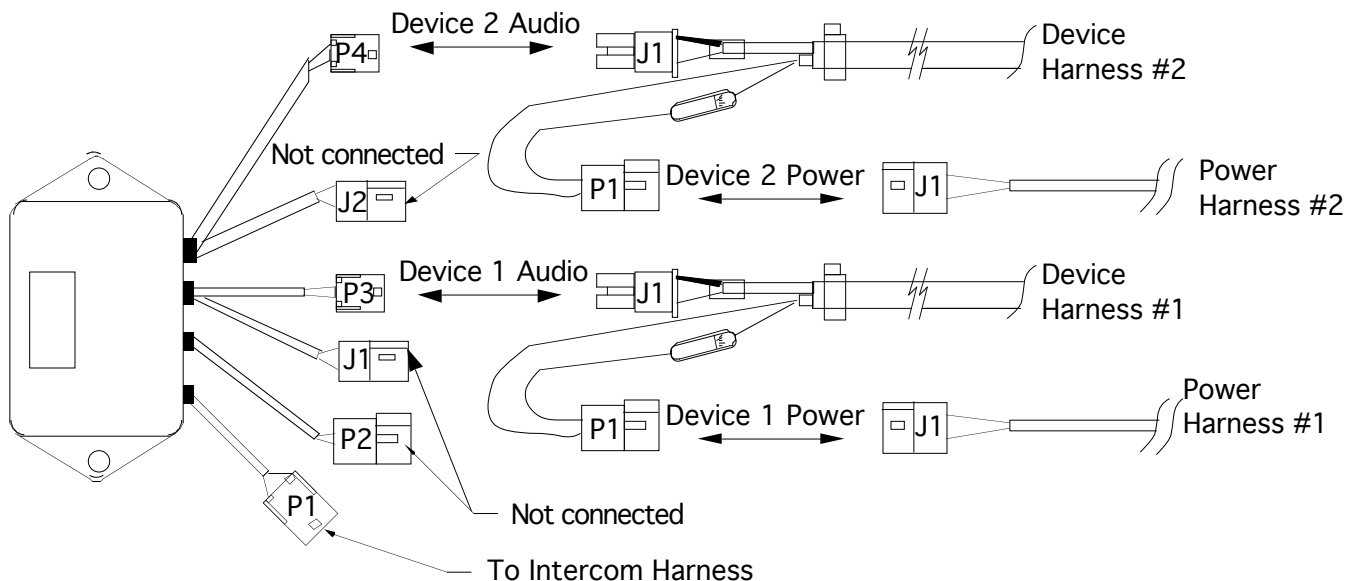

Figure 4. DualSet Connection - different power source